

MPSA06 TRANSISTOR (NPN)

FEATURES

- Power amplifier

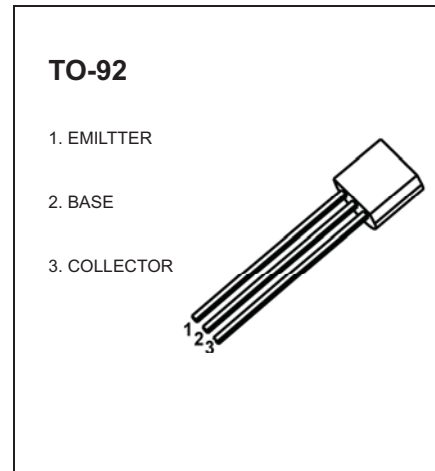

MARKING

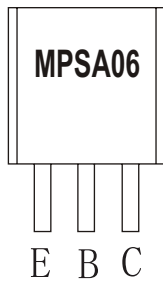

MPSA06=Device code
Solid dot=Green molding compound device,

Equivalent Circuit

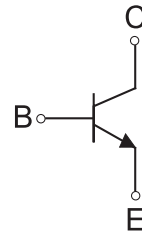

ORDERING INFORMATION

Part Number	Package	Packing Method	Pack Quantity
MPSA06	TO-92	Bulk	1000pcs/Bag
MPSA06-TA	TO-92	Tape	2000pcs/Box

MAXIMUM RATINGS (T_a=25°C unless otherwise noted)

Symbol	Parameter	Value	Unit
V _{CB0}	Collector-Base Voltage	80	V
V _{CEO}	Collector-Emitter Voltage	80	V
V _{EBO}	Emitter-Base Voltage	4	V
I _c	Collector Current -Continuous	0.5	A
P _D	Collector Power Dissipation	625	mW
R _{θJA}	Thermal Resistance from Junction to Ambient	200	°C /W
T _J , T _{stg}	Operation Junction and Storage Temperature Range	-55~+150	°C

ELECTRICAL CHARACTERISTICS

$T_a=25^\circ\text{C}$ unless otherwise specified

Parameter	Symbol	Test conditions	Min	Max	Unit
Collector-base breakdown voltage	$V_{(BR)CBO}$	$I_C=100\mu\text{A}$, $I_E=0$	80		V
Collector-emitter breakdown voltage	$V_{(BR)CEO}$	$I_C=1\text{mA}$, $I_B=0$	80		V
Emitter-base breakdown voltage	$V_{(BR)EBO}$	$I_E=100\mu\text{A}$, $I_C=0$	4		V
Collector cut-off current	I_{CBO}	$V_{CB}=80\text{V}$, $I_E=0$		0.1	μA
Collector cut-off current	I_{CEO}	$V_{CE}=60\text{V}$, $I_B=0$		0.1	μA
Emitter cut-off current	I_{EBO}	$V_{EB}=3\text{V}$, $I_C=0$		0.1	μA
DC current gain	h_{FE1}	$V_{CE}=1\text{V}$, $I_C=100\text{mA}$	100	400	
	h_{FE2}	$V_{CE}=1\text{V}$, $I_C=10\text{mA}$	100		
Collector-emitter saturation voltage	$V_{CE(sat)}$	$I_C=100\text{mA}$, $I_B=10\text{mA}$		0.25	V
Base-emitter saturation voltage	$V_{BE(sat)}$	$I_C=100\text{mA}$, $I_B=10\text{mA}$		1.2	V
Transition frequency	f_T	$V_{CE}=2\text{V}$, $I_C=10\text{mA}$ $f=100\text{MHz}$	100		MHz

Typical Characteristics

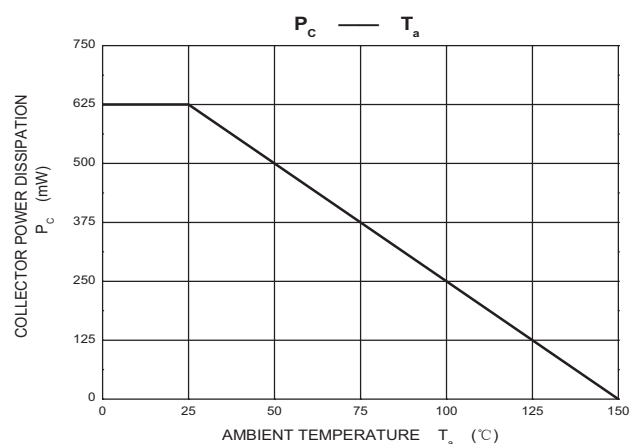
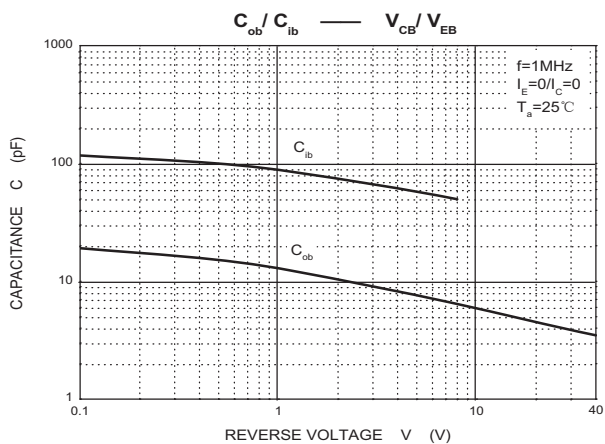
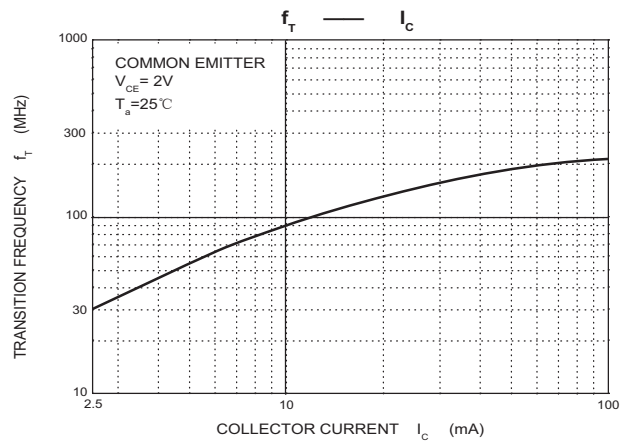
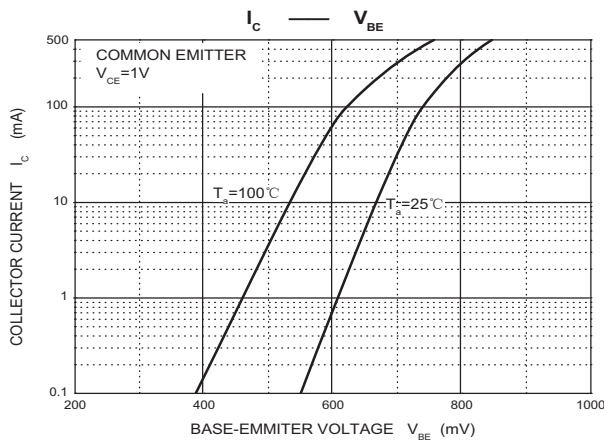
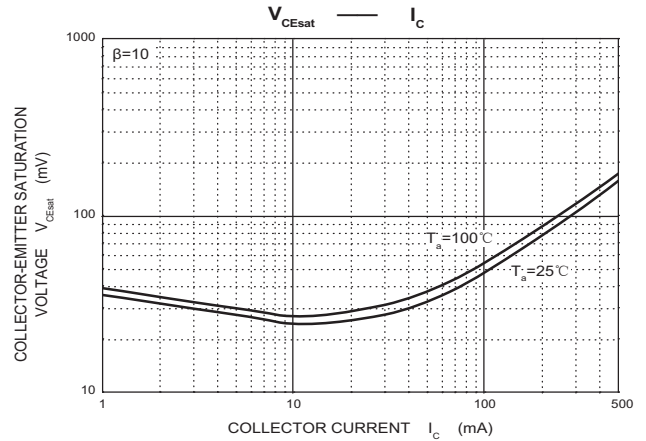
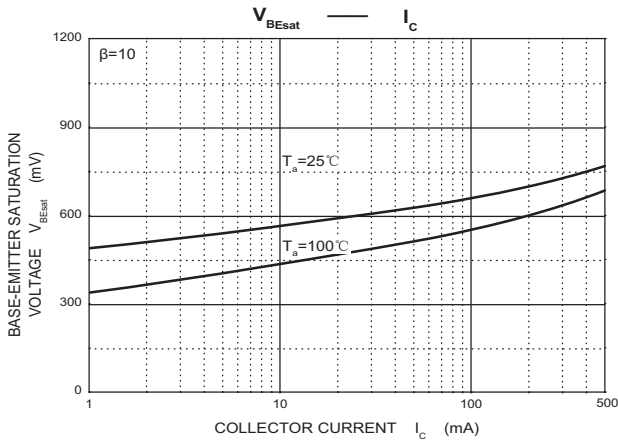
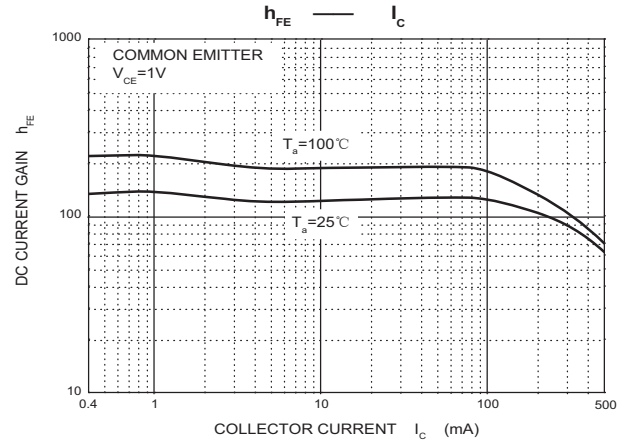
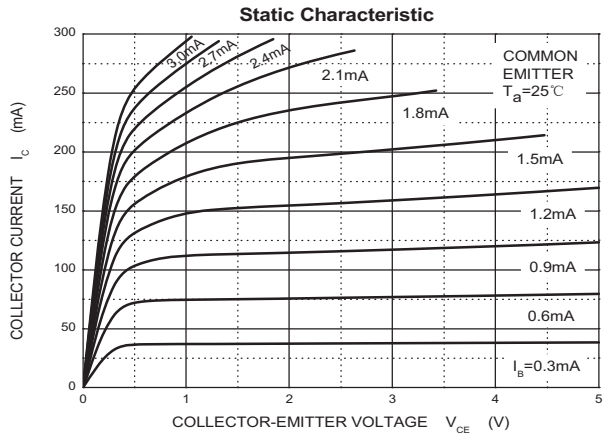

TO-92 Package Outline Dimensions

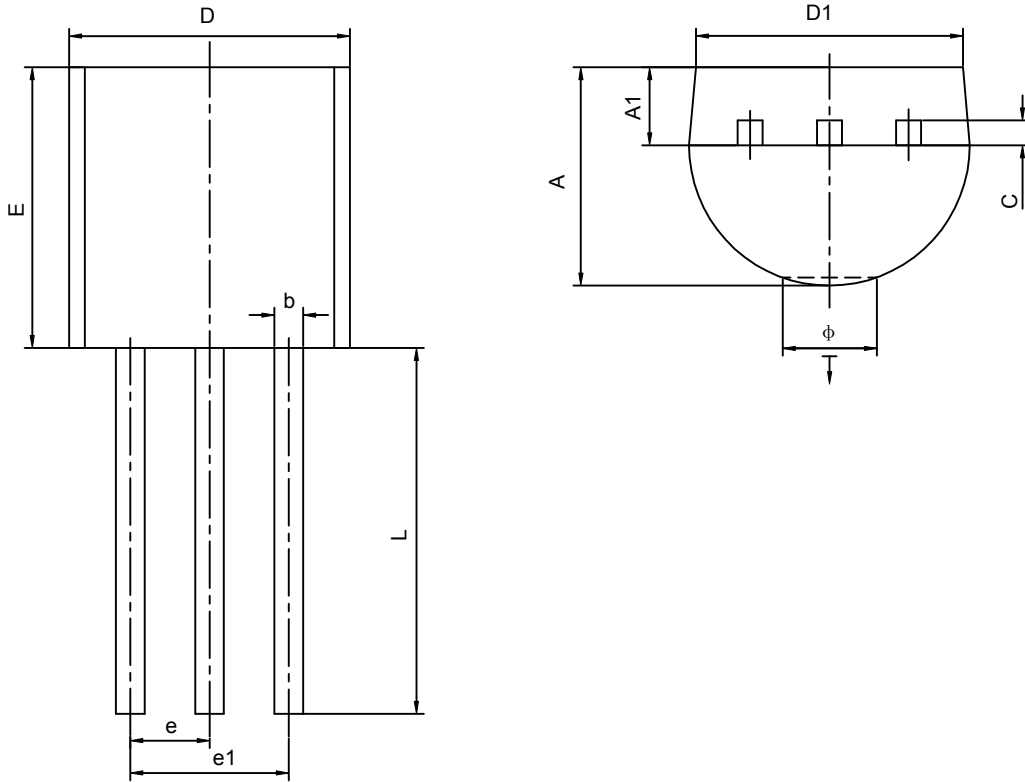

Symbol	Dimensions In Millimeters		Dimensions In Inches	
	Min	Max	Min	Max
A	3.300	3.700	0.130	0.146
A1	1.100	1.400	0.043	0.055
b	0.380	0.550	0.015	0.022
c	0.360	0.510	0.014	0.020
D	4.400	4.700	0.173	0.185
D1	3.430		0.135	
E	4.300	4.700	0.169	0.185
e	1.270TYP		0.050TYP	
e1	2.440	2.640	0.096	0.104
L	14.100	14.500	0.555	0.571
Ö		1.600		0.063
↓	0.000	0.380	0.000	0.015